

# F.A.T.C. NEWS

Florida Antique Tackle Collectors Newsletter

Volume 30, Number 3



*The Mystery  
of the  
Trolling Fin*



**The 20th Century Rod**



**Jan Cummings  
Presented Honorary  
Membership**



# Punta Gorda Summer Show June 2016

Many thanks to our Show Host Dick Braun.

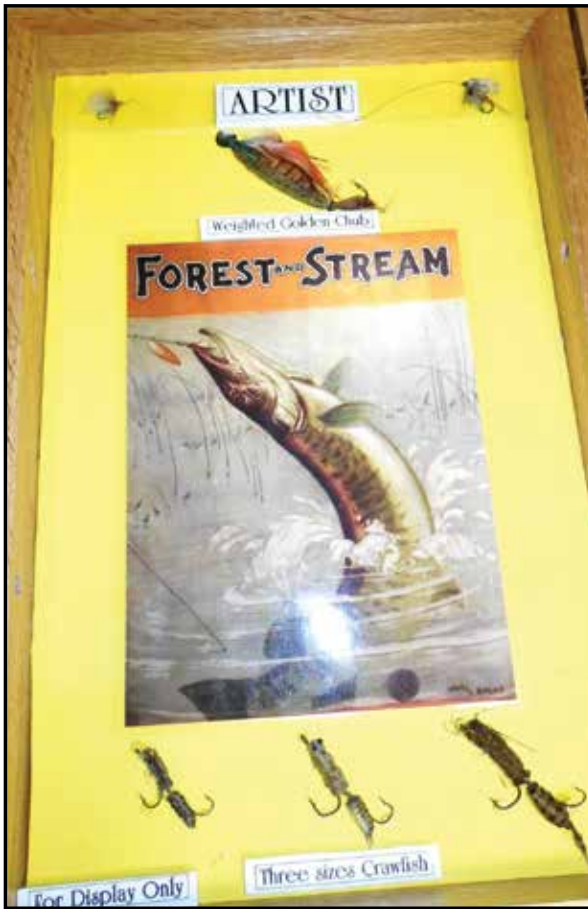

Mike Finch Lures



A Von Hoff Reel about to go



Jim Duncan's Pikes



Heddons



Ron Gast admiring Peter Heid's Tiny Lure Collection and Metal and Pearl Lures

## The World's Most Comprehensive Antique & Collectible Fishing Tackle Reference

Providing a quick, easy search for values and information on items in every fishing tackle and angling related category. Exclusively utilizing Lang's past auction catalogs - the most comprehensive database available for actual values on antique & collectible lures, reels, rods, flies, books, creels, floats, ephemera, fish decoys, etc.



Over a decade of Lang's Auction catalogs - hundreds of thousands of photos, descriptions and actual prices realized, with updates and new items added automatically after every auction.



Visit [TackleFindApp.com](http://TackleFindApp.com) from your PC or Mac  
Download the App from your mobile device Today



Now you're only seconds away from the information you need to buy or sell with confidence - at a show, estate sale, buying online or at an auction, the identification and value you need is as close as your phone, tablet or computer. Research actual prices paid, ascertain common vs. rare, find value differences per condition, explore trends, and much more. Equal to a library of reference books for your immediate use, no matter where you are or when you need information - never sell a rare item for less than its actual value again, and don't be fooled into buying a common example for a price that should be reserved for a rare color, scarce size, or valuable variation.

*The only field reference for antique and collectible fishing tackle you'll ever need!*



Unlimited searches and access - monthly subscription \$4.99 • 24hr unlimited searches - \$1.99 • [TackleFindApp.com](http://TackleFindApp.com)



A toast for the newlywed Ed and Sheila Weston



Robert Coons Glass Minnow



Mike Sims Millsite Rattlebugs



Jan Cummings Lures



Bill Premazas Creek Chub Beetles



Steve Cox helping Russ Griffins widow



More of Robert Coon Glass Minnow

# Punta Gorda Show Winners



Best Educational - Jim Duncan



Best Topical - John Kasulaitis



Best Florida - Ron Gast



Bill Premazas Pflueger Reels



Bill Premazas Shakespeare Reels



Coach Toms 1859 Reels



Robert Coons Old Tackle Box



Some of Ed Pritchard's Reel Display



John Kasulaitis Beautiful Lure Cabinet



Some of Butch Carey's Reel Display



Jan Cummings Lures

# FATC Awards Criteria

It has come to our attention that many of our FATC members are not aware of the various benchmarks used to judge the exhibits at our FATC shows. The following is a synopsis of the criteria used to reach our decisions:

- Educational Information
- Identification & Labeling
- Rarity
- Completeness
- Condition
- Overall Presentation
- Uniqueness and/or Originality

An exhibitor who wins a major award at one show is not eligible to win another major award for the same or similar exhibit for a period of one year. This exhibitor however, may win a major award within this time period if they display an exhibit that is entirely different.

Exhibit cards with the name of the exhibit and the owners name should be displayed prominently on their exhibit. These cards can be obtained at the registration desk.

Thank you,  
Awards Committee – Rick Vaughn and Paul Snider

## WANTED TO BUY OR TRADE

**SOUTHERN BAIT COMPANY,  
FLORIDA LURE BOXES, LURES OR  
LITERATURE**

**Frank Carter, Tallahassee, FL  
850-574-9718 email: fandi@comcast.net**



# F.A.T.C. NEWS

**The Newsletter of the Florida  
Antique Tackle Collectors, Inc.**

August 2016 Volume 30, No. 3

## Contents

Punta Gorda Summer Show Photos ..... 2-7

President’s Message ..... 9

Editor Notes ..... 10

Jan Cummings Presented Honorary Membership.. 11-14

The 20th Century Rod..... 16-17

The Mystery of the Trolling Fin ..... 18-19

The 26th “Florida International” Show Flyer ..... 20-22

St. Pete Beach Show Flyer ..... 23

**PRESIDENT...** Mike Hall, Jacksonville, FL  
**VICE PRESIDENT...** Chuck Heddon, Longwood, FL  
**SECRETARY...** Rick Vaughn, Nokomis, FL  
**TREASURER...** Sally Jett, Sebring, FL  
**ADVERTISING...** Paul Snider, Pensacola, FL  
**DIRECTORS...**

Paul Snider, Pensacola, FL	Ron Gast, Kissimmee, FL
Norm Pinardi, Bradenton, FL	Dennis McNulty, Sebastian, FL
Jim Duncan, Palm Beach Gardens, FL	Rick Vaughn, Nokomis, FL
Mike Hall, Jacksonville, FL	Butch Carey, Key West, FL
Chuck Heddon, Longwood, FL	Beth Lucas, Daytona Beach, FL

F.A.T.C. News is published tri-annually by F.A.T.C., a voluntary, non-profit corporation. Past issues can be viewed online at our web site: [www.fatc.net](http://www.fatc.net)

### F.A.T.C. NEWS EDITOR

Johnny Garland  
 109 Oscar Miller Rd., Johnson City, TN 37604  
 423-943-3333  
 email: [bagleyfanatic@gmail.com](mailto:bagleyfanatic@gmail.com)

Printed by Alta Systems, Inc., Gainesville, FL  
 The material in the F.A.T.C. News is copyrighted and cannot be reproduced in any manner whatsoever without permission.





## President's Message

Mike Hall



Punta Gorda... What a great location for an F.A.T.C. Show, riverfront hotel with docks to fish from, and sunsets at Hurricane Charley's raw bar & grill at the hotel, named after Hurricane Charley that wreaked havoc on the Port Charlotte area in August 15, 2004.

Our Show Host, Dick Braun and Butch Carey put together a great show, with the room full of tables, and a few auctions done by (our auction guy), Dennis McNulty. During the Awards Ceremony, Bill Stuart an Honorary Member himself awarded our own very talented lure maker Jan Cummings as our newest Honorary Member. Jan's artistic creations are highly sought after, and destined to become the lure maker to collect. Bill Stuart gave an informative, and personal bio on Jan, very nice presentation. I can email a copy to any Jan Cummings lure collectors, nice read about Jan.

Speaking of Mr. Bill Stuart, Bill has graciously decided to auction off his Florida lure collection at The Daytona Show. This auction will be held Saturday night March 4, 2017, reformed Live on line auction by Lang's Auction. Approximately 200 lots, subscribers to Lang's will receive information e-mail of details and pictures of lots. We will also have our Club auction on Friday night, March 3rd. Two big auctions at one show.

St. Pete Beach show is just days away, looking forward to returning to the Dolphin Beach Resort, hosted again by Ron Gast always a great show. Come on down and experience that "green flash" sunset at the tiki bar. Hope to see you there. 🐟



- Private charters
- Custom rigged, fully equipped safe bass boat
- Half day, full day and night fishing trips
- Free tackle and lures
- Free refreshments
- Free Transportation from most hotels
- Free photo of your fish
- USCG master captain license

• No Fish-No Pay! •



[www.centralfloridafishing.com](http://www.centralfloridafishing.com)

### Bill Long's Fishing Guide & Lake Tour Service

1630 Balmy Beach Drive  
Apopka, Florida 32703

Phone: (407) 290-1593

Email: [info@centralfloridafishing.com](mailto:info@centralfloridafishing.com)



Come see why Central Florida is known as the world's best trophy fishing destination. Captain Bill Long has fished these Central Florida waters for over 30 years. Bill specializes in both artificial bait and shiners to catch **BIG BASS** and Black Croppie (Speckled Perch).

Bill Long's Fishing Guide is featured in Florida Sportsman, Outdoor Life, Field and Stream, and has appeared on ESPN's Wayne Pearson Ultimate Outdoors. Having you land big trophy bass is our number one priority.

If you are interested in seeing Central Florida's beauty by boat, call for your special sightseeing tours. Bring your camera as you will see old Cypress Trees, Spanish Moss, Water Hyacinths, birds, wildlife and alligators.

Our central location puts you 30 minutes or less from major attractions such as: Disney World®, MGM, Epcot, Universal Studios, and Sea World.

## Editor Notes

*Johnny Garland*

I am sure we all have memories of fishing, fishing lures and fishing experiences which will always remain with us. I have lost a son, a mother, a dad and a grandfather to whom I was very close. With each, I have at least one fond memory of fishing. The one which I miss the most is my Dad.

When I was between 6 and 8 years old my Dad introduced me to fishing. During those years he took me fishing at a lake and watched my every move, especially my handling of fish hooks.

There was a very nice creek which flowed in front of our house that had minnows - shiners, red-sided and honney-heads. I was allowed to go to the creek and fish alone and/or with my little brother. However, in those early years I was not allowed to have a store-bought hook. Dad would take a straight-pin and bend it with a small pair of pliers which he carried in his pocket until the day he died. (Those pliers even went with him to Church). He would tie kite-string beneath the head of the pin and use a small nut from his shop as a sinker. He would then tie that to a short cane pole. I would turn rocks, lumber or dig to find red worms and off to the creek I would go.

I always begged for a real hook, but Dad would not allow it for those first couple of years. He always said, "you may get a hook in your hand and I cannot afford to miss work to come home to take you to the hospital". I always responded, "no, I won't".

One very clear memory I have: I was fishing through a spacing in a wooden bridge with slats. There was a fairly deep hole which had some nice honney-heads beneath the bridge. I hooked a big one and got him up to the spacing of the slats, he would not come through the opening - too big. I was able to keep him on the hook (pin) for awhile, but not through the slats. Finally, he fell off and back into the creek. I remember in anger thinking - if Dad had only allowed me one of his hooks this fish would not have come off. Then in anger I smacked the bridge in disgust. On that bridge laid my pin, nut and string. I not only smacked the bridge, I also smacked the pin by mistake. Into my hand went the "hook" about as far as it could go.

I don't think I ever told my Dad - "you were right", but he left me a wonderful fishing memory.

See you in St. Pete - let's make a memory.  
Johnny 

### "REELS AS BIG AS YOUR HEAD"



**Always Buying Big Game Reels, Rods, and all Misc. Big Game Tackle**

Trophies, Gaffs, Pins, Patches, Hooks, Misc. South Bend "Zane Grey" Teasers & All Teasers

**Also Paying Top Dollar For High Quality Fly Fishing Reels to include:**

Hardy, Meek, Zwarg, Vom Hofe, Walker, Mills, Leonard, Philbrook & Payne & All Others

**BUYING HIGH QUALITY SALT WATER REELS**

*Please Contact:*

**Ed Pritchard - 561-748-7508 or 561-818-1081**

Visit us at - [AntiqueFishingReels.com](http://AntiqueFishingReels.com)

Or E-Mail - [reeltackle@aol.com](mailto:reeltackle@aol.com)

### WANTED

Ralph Miller Leaping Lena's  
Will Buy Individual Bait  
Or Collections



My Grandfather made these Lures in a two story garage behind his house. I am trying to preserve his legacy. Call me anytime and lets talk. 214-554-6245 or email me at [windsurfer.bob@gmail.com](mailto:windsurfer.bob@gmail.com) check out [LeapingLena.com](http://LeapingLena.com)



# Jan Cummings Presented Honorary Membership in the FATC

*Bill Stuart*

Mr. Mike Hall, President FATC, does hereby present Jan Cummings for Honorary Membership in the Florida Antique Tackle Collectors.

Jan Cummings was born in Laurel, Mississippi, and lived on the Mississippi River until he was ten years old, first at Natchez and then in Baton Rouge, Louisiana. Then Jan's family moved to Iowa. After graduation from high school, he attended Northwest Missouri State. In 1973 he moved to Sarasota, Florida, to attend the Ringling School of Art.

Jan married Mary Kinane, a native of Syracuse, New York. They have 2 children, a son, Nathan, who this year is twenty-one and a daughter, Lydia, who will be eighteen. He had been a boat



*Mike Hall making the presentation to Jan*



# CERTIFICATE OF HONORARY MEMBERSHIP

*In The Florida Antique Tackle Collectors  
is awarded to*

*Jan Cummings*

*Mike Hall*

Mike Hall  
President

*Charles Heddon*

Charles Heddon  
Vice President

By the authority of the Board of Directors of the Florida Antique  
Tackle Collectors and presented at the Punta Gorda Show this  
18<sup>th</sup> day of June 2016.

carpenter since the late 1970's specializing in wooden boat construction and repair. Jan received his Offshore 50-ton Captain's License in 1995. In the early nineties Jan became enchanted with lure making. He studied every book he could find and was captivated not so much by the value of these lures but by their designs - he wanted to know did they actually work and if so how they actually worked, and the brilliant colors, and patterns. Jan asserts that, "There is a great similarity between building boats and making fishing lures. They are both built to perform in the water, and it helps to understand one to know the other."

His wood of choice is aromatic cedar; the metal he prefers is German silver. The sole exception to such preference was a fish decoy he made of basswood. Jan's metalized lures are electroplated over wood, just as they were in the early days of lure making. However, his painting materials are more modern with his use of airbrushing. He tests every one of his lures in the lake behind his house. If they do not work right you will never see the lure. Jan also makes all of his lure boxes, cardboard and wood.

Gary Smith wrote an article on Jan Cummings in March/April 2010 edition of *Hunting & Fishing Collectibles Magazine*, entitled Too Pretty to Fish: The Contemporary Fishing Lures of Jan Cummings. In his article Gary raises the question of whether, "Jan should be considered a craftsman or exalted to the realm of the artist."



Jan with the Certificate of Honorary Membership



Wofford College Fly Fishing Class

Gary goes on to write, "What sets Jan Cummings apart from other contemporary lure makers who cater to the collector market is not only the extraordinary beauty of his lures - the bright colors and patterns, the intricacy and symmetry of his designs, but the exceptional skill he exhibits in executing those designs."

Jan says, "To me the most satisfying activity of all is attending the fishing tackle shows where I can



see and admire the antique tackle on display and interact with the people who admire my work. That gets my adrenalin pumped!" His earliest memories of fishing are with his grandfather on Lake Boga Homa outside of Laurel, Mississippi.

Jan's work has been published in: the December 2003 NFLCC Magazine; *Hunting and Fishing Collectibles Magazine* by Gary Smith; *Fishing*

*Lure Collectibles* by Dudley Murphy; and *FATC News* by Bill Stuart.

This nomination is cosponsored by, Dan Basore, Karen and Art Edwards, Ralph Hecht, and Bill Stuart. We all anxiously wait to see what Jan will make next!

My summation is "Jan's design is in his head, his head is out of the box and over the top." 

**ZEBCO Collector**  
 Of Closed faced Zebco reels  
**Dick Braun**  
 1949-1999 USA Produced Reels  
Dick\_braun@embarqmail.com  
That-zebco-guy@embarqmail.com  
 941-639-8330  
 Member of ORCA, FATC & Author

(863) 956-3885  
 davidapple@juno.com



**APPLE'S HOME SERVICE**  
 Expert Lawn and Landscape Maintenance

David Apple  
 Owner

380 S. Seminole Ave.  
 Lake Alfred, Florida 33850

# Thanks to all who helped with my collection!

*~Chuck*

**WANTED:**  
*Genuine*  
**Heddon**  
**LURES**



FATC  
 NFLCC

(407) 862-7562

C. HEDDON  
 519 Sugar Ridge Ct.  
 Longwood, FL 32779



Cell: 321-439-4011

cheddon@mpinet.net



President: **Mike Hall**, 904-424-7071, flalake@aol.com  
 Vice President: **Chuck Heddon**, 407-862-7562, cheddon@mpinet.net  
 Secretary: **Rick Vaughan**, 941-223-8996, fishboy6500@yahoo.com  
 Treasurer: **Sally Jett**, sallyjett2@aol.com

Auction Chair: **Mike Mais**, 352-622-2868, mmais68569@embarqmail.com  
 Awards Committee: **Rick Vaughan**, 941-223-8996, fishboy6500@yahoo.com  
 and **Paul Snider**, 850-458-2111, paulsnider@cox.net

Advertising: **Paul Snider**, 850-458-2111, paulsnider@cox.net

Directors: **Dennis McNulty**, 757-576-6221, macslure@att.net, At Large

**Norm Pinardi**, 841-792-1671, njpinardi@aol.com, W, **Rick Vaughn**, 941-223-8996, fishboy6500@yahoo.com, SW

**Jim Duncan**, 561-575-7956, duncan694@aol.com, E, **Paul Snider**, 850-458-2111, paulsnider@cox.net, NW

**Mike Mais**, 352-622-2868, mmais68569@embarqmail.com, NE,

**Butch Carey**, 305-745-1873, butchcareykw@aol.com, SE

**Ron Gast**, 407-496-7940, ron@luresnreels.com, Central

Membership Director: **Beth Lucas**, 386-852-2946, beth@flowerscentral.com

FATC Newsletter Editor: **Johnny Garland**

109 Oscar Miller Rd., Johnson City, TN 37604, 423-943-3333, bagleyfanatic@gmail.com

<b>F A T C  A D  R A T E S</b>	Classified "Tackle box" ads (black & white)	\$3.50	1x	\$10.00	3x	<b>E F F E C T I V E  2 0 1 1 1 7</b>
	Classified "Tackle box" ads (color)	5.00	1x	12.50	3x	
	Business Card ads (black & white)	10.00	1x	29.00	3x	
	Business Card ads (color)	15.00	1x	40.00	3x	
	1/4 page ads (black & white)	50.00	1x	120.00	3x	
	1/4 page ads (color)	75.00	1x	200.00	3x	
	1/2 page ads (black & white)	90.00	1x	215.00	3x	
	Full page ads (black & white)	160.00	1x	380.00	3x	
	1/2 page color horizontal	200.00	1x	450.00	3x	
	Outside back cover – color (horizontal only)	275.00	1x	619.00	3x	
	1/2 page color (Contents page only – vertical)	300.00	1x	679.00	3x	
	Full page color (except covers or center)	375.00	1x	900.00	3x	
Inside front or back cover	525.00	1x	1,179.00	3x		
Single center page	450.00	1x	1,019.00	3x		
Centerfold (No vertical center gutter)	850.00	1x	1,919.00	3x		

## Florida Antique Tackle Collectors, Inc.

A NON-PROFIT EDUCATIONAL ORGANIZATION  
 DEDICATED TO THE PRESERVATION OF OUR ANGLING HERITAGE

Florida Antique Tackle Collectors, Inc. (FATC) is a non-profit, educational corporation, incorporated in the State of Florida. The purpose of FATC is educational through the collection and distribution of historical and technical data regarding fishing equipment, its development, its inventors and manufacturers from the earliest times through the present day, and to assist other groups and individuals having a similar purpose. In order to enhance the knowledge of these subjects, the collection and preservation of examples of fishing tackle is to be encouraged for the benefit of present and future generations.

FATC was founded in 1987. The founders felt that a state-wide organization would provide additional opportunities for residents of Florida and others to learn more about the history of angling in Florida and elsewhere. FATC sponsors four exhibitions, open to the public, annually at different Florida locations. At the exhibitions members display their

collections, interact with the public, and engage in other activities in keeping with the purpose of FATC. FATC publishes a newsletter tri-annually, and an annual membership directory. FATC is not affiliated in any way with the National Fishing Lure Collector's Club (NFLCC) or the Old Reel Collectors Association, Inc., (ORCA) but encourages FATC members to support those organizations.

FATC annual membership dues are: \$35 domestic, \$40 Canada, \$45 Foreign or \$700 (Domestic) Life Membership, \$800 (Canada) Life Membership, and \$900 (Foreign) Life Membership (20x annual dues). Please direct membership inquiries or applications (with your dues) to the FATC Secretary listed below. For membership applications visit our web site at: [www.fatc.net](http://www.fatc.net)

One time ads will be given a 3% discount for prepayment.

# The 20th Century Rod

Charlie Tanner

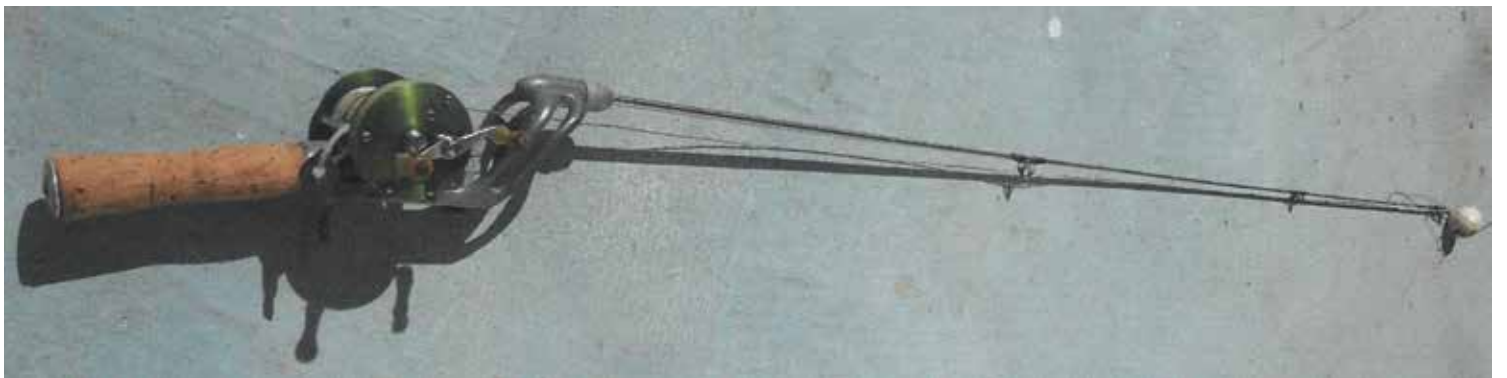

Back in the 40's steel rods were very popular. They already had a long history going back to the late 1800's. There are hundreds of patents with innovative ideas covering every part of these fishing rods. To keep the innovation on a roll Walter Rives came up with a very different plan. He invented and patented a reel handle that allowed the line to flow through guides mounted under the rod. Referred to in ads as, "under strung" guides.

Rives was very inventive. He held several patents including, a measuring disc for an oil container, a gas welding torch, a pulley and a housing for airport beacons. His patent No. 2,503,510 filed in January 1948 for the "20th Century Rod" gave a new look to the fishing rod.

It was very easy to use and works well. The design offered less friction between the line and rod. I used it to compete in a casting contest at an ORCA show. I didn't win, but I can't blame the rod.

In the May 1948 issue of the *Florida Wildlife Mag*

THE ROD THAT CHANGES "WISHING" to FISHING!

The  
20<sup>th</sup> CENTURY  
ROD

**CASTS  
25% FARTHER**

Casting with a 20th CENTURY ROD is like casting a ball bearing through clean air! There's no line drag . . . your reel rolls smoothly . . . your cast goes straight as a die WAY OUT THERE—where the BIG ones are! ALL because revolutionary 20th CENTURY and only 20th CENTURY CASTING RODS carry the line under the rod where it can't rub, snarl or cross! Eight ounces of pure ingenuity . . . in water-resistant, mildeer-proof carrying case . . . with "Egg-Size" foregrip.

"understrung"  
MAKES THE DIFFERENCE

W. L. RIVES CO.  
87 RIVERSIDE VIADUCT  
JACKSONVILLE  
FLORIDA

FULLY GUARANTEED • Solid or hollow steel • Models from 2 1/2 to 3 1/2 feet • File Any Make Reel • WRITE FOR FREE CATALOG



W.L. Rives Company operated a metal fabrication business in the 40's at 87 Broad St. Viaduct Jacksonville, Florida. In the 50's the city business directory has their location at 5400 Rio Grande Ave. Jacksonville, Florida 32254.

The company's board included; Walter L. Rives as President, Clyde Sharman Jr. Vice-President, Irwin Wittick Vice-President and Margaret Secretary Treasurer.

In my research I found several patents for handles that are for rods with under slung guides. Philip Mullins filed for his patent April 30, 1948 just three months after Rives filed his.

Similar patents covering the idea were filed in; Nov. 1961 No. 3,196,572 by J.R. Steinle and No. 4,130,960 filed in Dec. 1978 by Carl Pontenet. The value of the 20th Century in good condition should be in the neighborhood of \$30 to \$50. I wonder what's ahead for us in this 21st century?

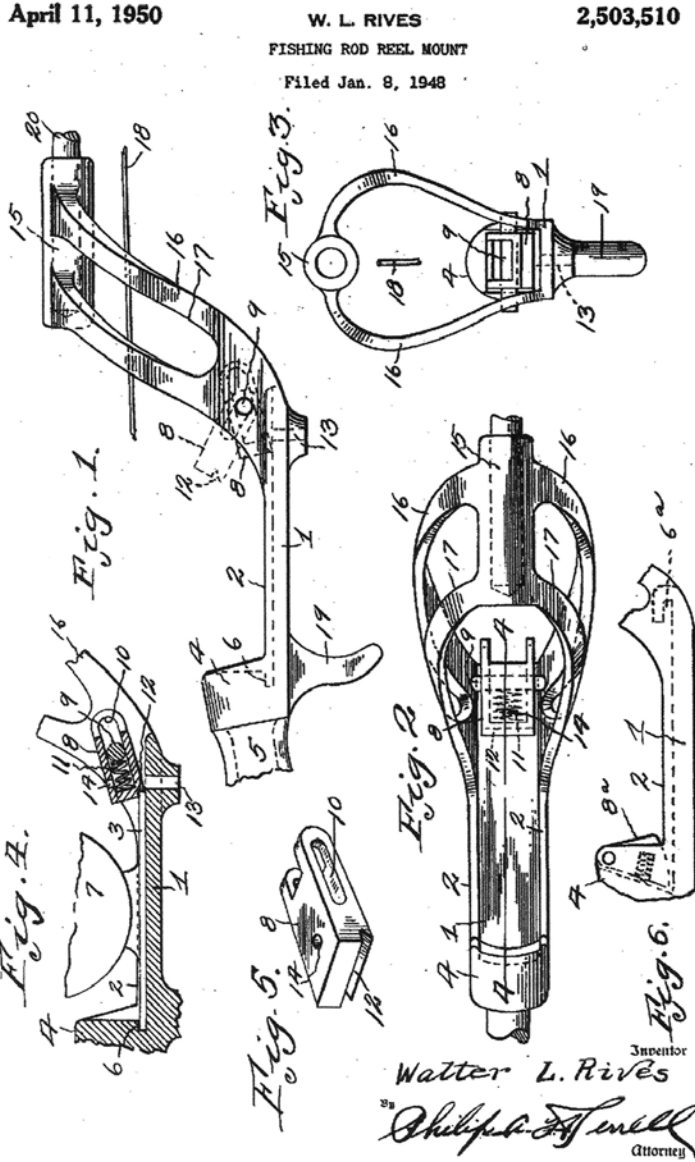

**April 3, 1951** **P. H. MULLINS** **2,547,655**  
**CASTING ROD HANDLE**  
 Filed April 30, 1948

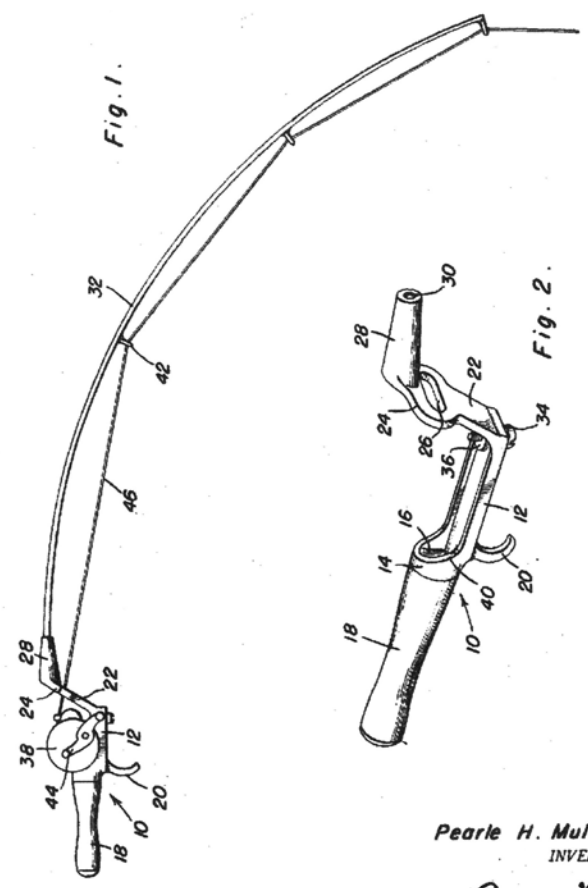

**Pearle H. Mullins**  
 INVENTOR.  
 BY *Thomas W. Dixon and Henry B. Jordan*  
 Attorneys

**The Fisher-Man**  
 Specializing in old reel parts.  
 Garcia Mitchell-Penn & more!

**Michael Arthur**  
 386-624-6920  
 813A Flightline Blvd. #6 • DeLand, FL 32724  
 TheFisher-Man@cfl.rr.com  
 www.thefisher-man.com  
 Tues-Fri Noon-6:00 • Sat 10:00-2:00

# The Mystery of the Trolling Fin

Frank Carter

Writing an accurate story about an early maker of fishing tackle requires patient research, some investigative skills, and often just getting lucky. It is not unusual to locate reliable documents that help you paint a pretty good picture, but some gaps often remain in verifying the whole story.

This is certainly true for the story of Frank Earl Fenderson of St. Petersburg, Florida.

Recently, while thinning out my Shakespeare collection, I came across a Shakespeare Trolling Fin in the envelope.

The envelope says that the trolling fin (No. 8906 C) is patented. Out of curiosity, I researched patents and found the 1929 patent filing by Frank Fenderson for a trolling fin. The patent was granted on March 3, 1931. This appears to be the only patent granted to Frank Fenderson, and there is no information regarding whether or not the trolling fin was ever made.

Further research revealed the following information from U.S. Census and other sources:

- Frank E. Fenderson was born in the state of New York on February 10, 1884. His father was Francis Albert Fenderson (1850 – 1937).
- Frank was married to Ruth M. Houghtling Fenderson (born in 1883) from Pennsylvania.
- They had a son Houghtling Earl Fenderson who was born and died in 1917.
- On a Registration Card completed by Frank in 1918, he gives a home address for he and Ruth at 121 6th Avenue North, St. Petersburg, Fl. He lists his occupation as self-employed real estate, with an office address at 143rd Street North.
- The 1930 census indicates that Frank was a fire insurance agent and did not serve in the military.
- The 1940 census indicates that Frank is president of a real estate company.
- Frank died in St. Petersburg, Florida, on January 13, 1942.
- Ruth died in 1958.

The Evening Independent, St. Petersburg's first daily newspaper, wrote several stories about Frank Fenderson, referring to him as "one of St. Petersburg's most famous fishermen." He was the uncle of Robert Fenderson Bullard who developed the pink jig for catching pompano. The story on Robert F. Bullard is found in Volume II of *Florida Lure Makers and Their Lures*.

A favorite hangout for serious fishermen in St. Petersburg from 1935 till 1942 was Hinson's Sporting Goods. Famous lure





maker and fishing guide Frenchy Chevalier was a regular along with Frank Fenderson and Bob Bullard. When Frenchy died in 1940, Frank Fenderson was one of the pallbearers.

The March 6, 1931, edition of The Evening Independent contained a story titled "FIN FOR TROLLING LINES IS INVENTED". It reported that F. Earl Fenderson of Fenderson Mortgage & Realty Co. has been granted a patent for a new type of trolling fin. The article concludes by saying that Fenderson has not yet decided whether to assign the device for manufacture in St. Petersburg or sell the patent outright.

It appears probable that Frank Fenderson sold his patent rights to The Shakespeare Company. The bottom of the Shakespeare envelope contains a second number – 1934. Perhaps that is the year they acquired the patent. 🐟

March 3, 1931.

F. E. FENDERSON

1,795,205

TROLLING FIN

Filed Feb. 6, 1929

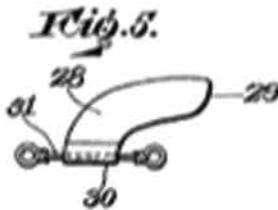
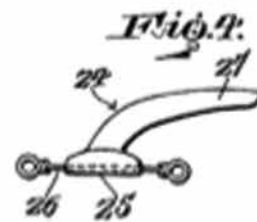
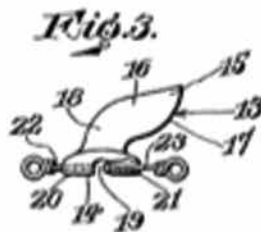
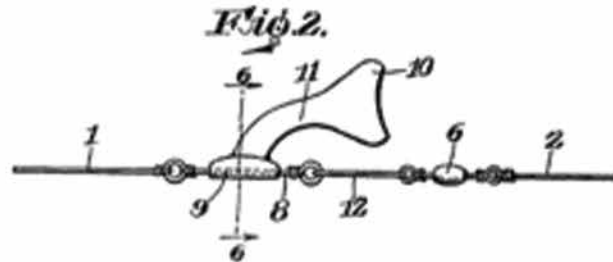
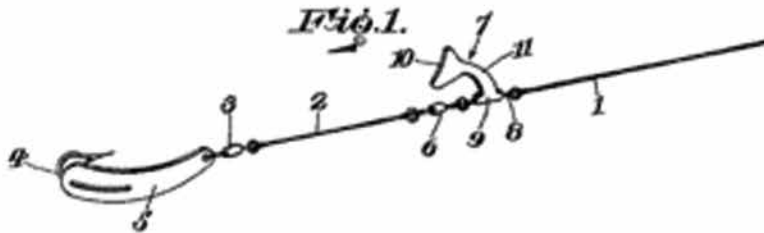

Fig. 6. INVENTOR,  
**Frank E. Fenderson,**  
 BY  
*Geo. P. Kimmel*  
 ATTORNEY.

Inventor: Frank E. Fenderson of St. Petersburg, Florida

**REELS AS BIG AS YOUR HEAD**

Specializing in Big Game Fishing Reels, Tackle & Memorabilia  
 Buying All High Quality Vintage Fishing Reels – Fly – Kentucky

- ED PRITCHARD -

Phone: 561-748-7508 Cell: 561-818-1081  
 E-Mail: [reeltackle@aol.com](mailto:reeltackle@aol.com)

Visit me on the web at: [AntiqueFishingReels.com](http://AntiqueFishingReels.com)



**ANTIQUE  
 BIG GAME  
 FISHING TACKLE**

← BUTCH CAREY →

Buying/Selling Vintage  
 Reels, Rods, Tackle  
 and Memorabilia

305-745-1873  
[butchcareykw@aol.com](mailto:butchcareykw@aol.com)  
 Key West, Florida

# THE 26<sup>th</sup> “FLORIDA INTERNATIONAL” TACKLE SHOW

Daytona Beach, Florida  
March 3<sup>rd</sup>, 4<sup>th</sup> & 5<sup>th</sup>, 2017

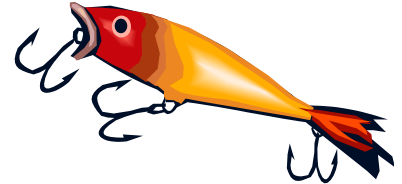

Return for the SUN,  
Return for the FUN,  
Return for the ANTIQUE FISHING TACKLE!

The F.A.T.C. “Florida International” will again be back to the Plaza Resort and Spa on the beach in Daytona Beach.

Join antique fishing tackle collectors from around the world for America’s second largest show. Join us for over 300 tables of antique lures, reels, rods, creels, fish decoys and much more including our Saturday Night Auction.

Here is your chance to escape the frigid north, and enjoy the warm tropical breezes and watch the waves roll up on the beach while buying and selling old fishing tackle.

Truly tackle trading in PARADISE!

The Plaza Resort and Spa is located right on the Atlantic Ocean and has two restaurants, a small convenience store, a very large pool facing the ocean, and dozens of great restaurants within walking distance. Orlando and its many theme parks are only an hour away.



Here is news about some of the exciting things planned for the 2017 “Florida International” Tackle Show in Daytona.

**SHOW HOST** -There has been a changing of the guard. Larry Lucas, after 10 years of dedication to making the “Florida International” one of the premier tackle shows in the country, is turning over the reins to me. I have big shoes to fill but I promise to do my best to continue on the traditions.

**AWARDS** - Awards this year will be Best of Show (selected by the members), Best Reel Display, Best Florida Display, Best Educational Display, Reverend Bob Dennis Best Topical Display and the Jack Funderbuck Award for Best Non-Florida Display.

2017 Special Award Categories

- Heddon Fishing Tackle
- Critters (frogs, mice or anything you think is a critter)

**EARLY ACCESS** – The early access was such a success at the 2016 show we again will offer this added service to our members. We will open our showrooms on Thursday night, the 2<sup>nd</sup> to allow you to bring in your displays & tackle. This will not be for set up, just bring it in and drop it at your tables. The F.A.T.C. will pay for security that night to make sure your valuables are safe. We will announce prior to the show dates the exact time we will be open on Thursday night.

**PUBLIC** - Public attendance at the 2016 show was up 20%. We will once again open to the public Friday from 11am-4pm and Saturday 9am-3pm. We signed up a lot of new members at the 2016 show.

I look forward to seeing everyone in March, if not sooner.

All the best,

Mike Hall



# “THE 26<sup>TH</sup> FLORIDA INTERNATIONAL”

## March 3<sup>rd</sup>, 4<sup>th</sup> & 5<sup>th</sup>, 2017

AT THE PLAZA RESORT AND SPA

600 NORTH ATLANTIC AVENUE, DAYTONA BEACH, FL. 32118

FATC NIGHTLY RATES - \$115/city or ocean view, \$125/ocean front, \$135 ocean front suites

These rates include a resort fee which entitles you to FREE PARKING, one-time \$12.00 drink credit, Wi-Fi, access to in-house fitness center, pool towels and chairs and in-room safes. Local and State taxes are extra.

**TOLL FREE 866-500-5630 or 855-327-5292**

*Make sure to mention Florida Antique Tackle Collectors for the special rates*

*Special room rates are good through January 29<sup>th</sup>*

**Please note:** Thursday night the 2<sup>nd</sup> we will be open for drop off of displays and tackle. Sunday the 5<sup>th</sup> will be primarily for breakdown. We will open to the Public Friday from 11am-4pm & Saturday 9am-3pm. Check [www.fatc.net](http://www.fatc.net) closer to the show for exact times and schedule.

Payable by PayPal, Credit Card or check

- PayPal or Credit Card - Go to [www.FATC.net](http://www.FATC.net) to complete registration and payment
- Checks - Make payable to **FATC** and mail to:  
Mike Hall  
2435 Ironwood Dr.  
Jacksonville, FL 32216-1217

Show host – Mike Hall 904-424-7071 or [flalake@aol.com](mailto:flalake@aol.com)

### REGISTRATION FORM

Please Print Clearly

Name: \_\_\_\_\_

Address: \_\_\_\_\_

City, State, Zip Code: \_\_\_\_\_

Telephone # & e-mail address: \_\_\_\_\_

Guest Name for Badge: \_\_\_\_\_

I'd like to reserve \_\_\_\_\_ Aisle Tables 8' @ \$35.00 Each \_\_\_\_\_

\_\_\_\_\_ Wall Tables 8' @ \$35.00 Each \_\_\_\_\_

Registration Fee (Includes one guest) \$15.00 \_\_\_\_\_

Membership dues (if unpaid) \$35.00 (US) \_\_\_\_\_

**TOTAL ENCLOSED \$ \_\_\_\_\_**

Special needs or requests? \_\_\_\_\_

**REFUNDS** for cancellations must be requested 30 days in advance. **CANCELLATIONS** after 30 days will not be refunded. You must be an FATC member to exhibit, trade or buy at the auction. **BREAKDOWNS** -In an effort to give the public a better show, we are asking anyone with tables to wait until after 4pm on Saturday to break down. Emergency exceptions will be made only by the show host. If you chose to break down early, you may not get a table next year.

# FATC Member Show Registration Form

## Dolphin Beach Resort, 4900 Gulf Blvd., St. Pete Beach

### August 26 – 28, 2016



Hotel: Phone 1-800-237-8916 ask for the Florida Antique Tackle Collectors Block or G/FATC/2016. Rates are \$109 (standard) and \$139 (poolside) 30 days prior.  
Website: [www.dolphinbeach.com](http://www.dolphinbeach.com)

Make check payable to FATC and mail to:

Ron Gast  
 9748 Hatton Circle  
 Orlando, FL 32832  
 Phone: 407-496-7940  
 Email: [ron@luresnreels.com](mailto:ron@luresnreels.com)

Friday: Members Only 8AM – 7PM  
 Open to Public 9AM – 5PM

Saturday: Members 8AM – 7PM  
 Open to Public 9AM – 5PM

Sunday: Exhibit tear-down

**You must be a member of FATC to exhibit or trade.**

Name \_\_\_\_\_

Address \_\_\_\_\_

Telephone # & email address \_\_\_\_\_

Guest Name(s) \_\_\_\_\_

Tables: \_\_\_\_\_ Wall Tables @ \$35 Each: \_\_\_\_\_

\_\_\_\_\_ Aisle Tables @ \$35 Each: \_\_\_\_\_

Membership Dues (if unpaid): \$35 \_\_\_\_\_

Prepaid Member Registration Fee: \$15 (\$20 at Show) \_\_\_\_\_

TOTAL ENCLOSED: \_\_\_\_\_



PRSRT STD  
US POSTAGE  
PAID  
PERMIT NO 702  
GAINESVILLE FL

## The FATC News

109 Oscar Miller Rd.  
Johnson City, TN 37604

## CALENDAR OF EVENTS



### St. Pete Beach Show

August 26 - 28, 2016  
Dolphin Beach Resort  
4900 Gulf Blvd, St. Pete Beach  
1-800-237-8916

### 2016 FATC Club Patch



### 26th Florida International Tackle Show

March 3 - 5, 2017  
Daytona Beach, FL  
Plaza Resort and Spa  
1-866-500-5630



**Dixie Bait Co. Darter in Silver Flash**